

Model 921 Single Gas Analyzer

THE NEED

The Model 921 is a rugged single gas analyzer housed in a single 19-inch, rack-mounted unit which can be integrated into CEM systems or used alone for a variety of gas monitoring applications. The Model 921's no-moving-parts design was specifically developed to enable the high sensitivity, low concentration measurements required by the latest environmental regulations.

The Model 921 can be configured to measure most gas species that absorb in the UV. The optional multiple-pass gas cell provides longer path length for measuring lower concentrations. For example, the minimum full scale for SO₂ is 25 ppm, with an accuracy of 1% of full scale.

The simple and robust design of the Model 921 is complemented by powerful data processing capabilities. The user-friendly keyboard enables programming of such variables as timing and frequency of local zero and span checks and calibration gas values. A serial communications interface enables direct interfacing with data acquisition and control systems using Modbus protocol.

When your requirement is for a rugged, low concentration, gas analyzer, free of interferences from water and CO₂, the Model 921 is your answer.

THE MEASUREMENT

The Western Research® Model 921 uses our proprietary high resolution UV technology in a dual beam, dual wavelength configuration. The major innovation in the Model 921 is that it is a true dual beam, dual wavelength analyzer with no moving parts. Instead of using a filter/chopper wheel to alternate between measure and reference wavelengths, the Model 921 uses a fixed optical configuration and pulsed UV lamps. This leads to increased light throughput, reduced noise levels, and reduced maintenance. The dual beam configuration combined with the reference measurement ensures low noise performance with minimal baseline and span drift.

Resolution better than 0.02 nm is provided by high intensity, line source lamps. These sources emit at a fixed wavelength, providing great measurement stability, and emit low total power, removing the potential for sample photolysis. The high resolution enables unparalleled linearity over a wide dynamic range (less than 1% deviation over 4 to 5 orders of magnitude) which, in turn, leads to simple, robust data analysis.



Model 921 Single Gas Analyzer

BENEFITS

- **No moving parts**
 - Reduced noise levels and maintenance
- **Accuracy better than 0.25 ppm SO₂**
- **Excellent baseline stability, minimal span drift**
- **Linearity better than 1% over 4 orders of magnitude**
- **No interference from H₂O and CO₂**
- **Optional O₂ measurement**
- **Serial communication with plant DCS**

APPLICATIONS

- **Source testing**
- **Continuous emissions monitoring, new and retrofit**
 - Low range SO₂
- **Manufactured gas QA**
 - Calibration, medical, and industrial gases
- **SRU tail gas clean-up**
 - H₂S and SO₂
- **Research**

PERFORMANCE SPECIFICATIONS

Methodology: Dual wavelength, high resolution, nondispersive UV

Species Measured (see Note 1)	Minimum Full Scale (see Note 2)	Maximum Full Scale
SO ₂	25 ppm	100%
NO	25 ppm	100%
NO ₂	50 ppm	100%
H ₂ S	50 ppm	100%

Note 1: Other species include: NH₃, COS, CS₂, mercaptans.

Note 2: Minimum full scale is based on ±1% full scale accuracy over 24 hours with auto zero disabled.

Optional O₂: Integral Paramagnetic sensor

Accuracy: Better than 1% full scale

Reproducibility: Better than ±1% of full scale

Linearity: Better than ±1% of full scale

Response Time: Typically less than 30 s to T90 (excluding sample system)

Number of Gases: Single gas analyzer

Typical Sample Flow: 1 to 2 l/min (2.1 SCFH)

Sample Gas Temperature: Ambient

Pressure and Temperature Compensation: Optional

Ambient Conditions: 41° to 122°F (5° to 50°C); 5 to 95% relative humidity, non-condensing

Zero Drift: Less than 0.5 ppm in 24 hours (for SO₂ only)

Power: 120 VAC ±10%, 47 to 63 Hz or 220 VAC ±10%, 47 to 63 Hz 90 W

Communications:

Analogue: 4 x voltage outputs, any combination

0 to 100 mVDC, 0 to 1 VDC, 0 to 10 VDC

4x 4-to-20 mA self-powered outputs optional

Digital: One RS232 port for service diagnostics

One RS422 with Modbus protocol (optional)

Physical Dimensions: 7 x 19 x 23.5 in. (180 x 480 x 600 mm)

Weight: Approximately 27 lbs. (12.3 kg) (varies with classification)

Approvals and Certifications: General purpose

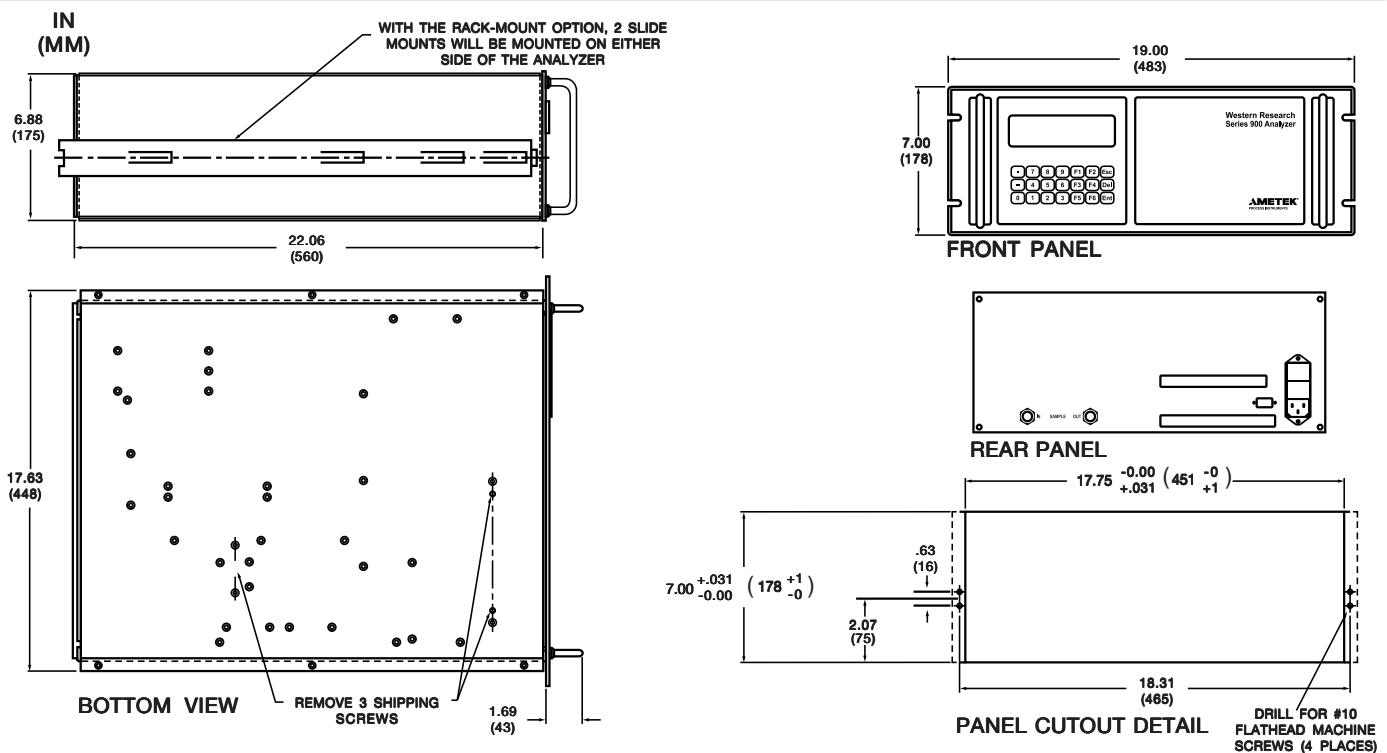

One of a family of innovative process analyzer solutions from AMETEK Process Instruments. Specifications subject to change without notice.



CANADA
2876 Sunridge Way N.E.
Calgary, AB T1Y 7H9
Ph. 403-235-8400
Fax 403-248-3550

USA - Delaware
455 Corporate Blvd.
Newark, DE 19702
Ph. 302-456-4400
Fax 302-456-4444

USA - Pittsburgh
150 Freeport Road
Pittsburgh, PA 15238
Ph. 412-828-9040
Fax 412-826-0399

USA - Texas
9750 Whithorn Drive
Houston, TX 77095
Ph. 281-463-2820
Fax 281-463-2701

CHINA
Ph. 86 21 6426 7049
Fax 86 21 6426 7054

FRANCE
Ph. 33 1 30 68 69 20
Fax 33 1 30 68 69 29

GERMANY
Ph. 49 21 59 91 36 0
Fax 49 21 59 91 36 80

MIDDLE EAST - Dubai
Ph. 971-4-881 2052
Fax 971-4-881 2053



www.ametekpi.com

© 2002, by AMETEK, Inc. All rights reserved.
921 (08/21/02)