



**TELEDYNE INSTRUMENTS**  
*Advanced Pollution Instrumentation*  
A Teledyne Technologies Company

MODELS **101E / 102E**

# H<sub>2</sub>S & TRS Analyzers

*for Ambient Air Quality Monitoring*



- ▶ **0-50 ppb to 10 ppm (101E), 0-50 ppb to 10 ppm (102E) ranges, user selectable**
- ▶ **Microprocessor controlled for versatility**
- ▶ **Multi-tasking software allows viewing of test variables during operation**
- ▶ **Auto ranging, dual range and remote range selection**
- ▶ **Built in self checks and diagnostic capabilities**
- ▶ **Bi-directional RS232 allows remote reading or operation (optional RS-485 or Ethernet)**
- ▶ **Digital status outputs provide instrument condition**
- ▶ **Optional H<sub>2</sub>S/SO<sub>2</sub> or TRS/SO<sub>2</sub> switching capability**
- ▶ **Auto Zero System**
- ▶ **Adaptive signal filtering optimizes response time**
- ▶ **Temperature & pressure compensation**
- ▶ **Optional Calibration valves or permeation oven**
- ▶ **User friendly operation and set up**
- ▶ **Internal Zero Span**
- ▶ **Internal Datalogger**
- ▶ **Critical Orifices provide flow stability**

The Models 101E/102E provide a dependable, accurate and convenient method of measuring hydrogen sulfide or Total Reduced Sulfur (TRS) in levels commonly required for Ambient Air monitoring, offering ranges from 0-50 ppb to 0-10 ppm. Both analyzers convert sulfur gases to sulfur dioxide and measure concentrations using fluorescence technology.

The M101E is equipped with an internally mounted low temperature converter which converts H<sub>2</sub>S at a closely controlled temperature setting of 315 °C, leaving other gases unaffected. The M102E uses a high temperature converter, mounted externally to the analyzer, and operates at a temperature of 850°C. TRS components (typically, H<sub>2</sub>S, methyl mercaptan, dimethyldisulfide and methyl-disulfide) are all converted to SO<sub>2</sub> at this temperature, with efficiency greater than 98%.

Sample gas drawn into the analyzer first passes through a scrubber which removes all traces of sulfur dioxide. The converter then converts the components of interest to SO<sub>2</sub>. The resulting concentration for SO<sub>2</sub> is then measured by fluorescence. In the basic configuration, the analyzer may be programmed to read H<sub>2</sub>S concentration (101E) or TRS (102E) only. However, a switching option, showing H<sub>2</sub>S/TRS and SO<sub>2</sub> readings alternately, is available. Cycle times may be adjusted, and each reading is truly independent, having its own calibration slope and offset. A sample and hold circuit provides continual analog outputs for each channel. Calibration is simplified by the optional zero and span valves, which allow direct entry of calibration gases, or the optional permeation tube may be used to provide span checks. The analyzers feature auto zero which provides excellent zero stability.



# MODELS 101E / 102E

## H<sub>2</sub>S and TRS Analyzer

for Ambient Air Quality Monitoring

### Specifications

<b>Ranges:</b>	<b>101E:</b> 0 – 50 ppb to 0 – 10 ppm H <sub>2</sub> S or up to 20 ppm SO <sub>2</sub> ; <b>102E:</b> 0 – 50 ppb to 0 – 10 ppm TRS or 20 ppm SO <sub>2</sub> (Note: For ranges higher than 0-10 ppm, please consult Teledyne API)	<b>Converter Location:</b>	<b>101E:</b> Inside analyzer; <b>102E:</b> Remote, may be rack mounted
<b>Range Selection:</b>	Ranges are user selectable, and independent ranges are available for both components. Auto and dual ranging are available.	<b>SO<sub>2</sub> Scrubber Efficiency:</b>	> 98%
<b>Zero Noise:</b>	0.2 ppb (RMS)	<b>Dimensions (HxWxD):</b>	7" (178 mm) x 17" (432 mm) x 23.5" (597 mm) for analyzer. Model 102E requires same size for converter
<b>Span Noise:</b>	< 0.5% of reading (RMS) above 50 ppb	<b>Weight:</b>	<b>101E:</b> 41 lbs (18.3 kg); <b>102E:</b> 53 lbs (24 kg)
<b>Lower Detectable Limit (LDL):</b>	< 0.4 ppb	<b>Power:</b>	100v, 50/60 Hz (3.25A); 115V, 60 Hz (3.0A); 220-240V, 50/60 Hz (2.5A)
<b>Zero Drift:</b>	< 0.5 ppb / 24 hrs, 1 ppb / 7 days	<b>Pump:</b>	Internal
<b>Span Drift:</b>	< 0.5 % full scale / 24 hrs, 1% full scale / 7 days	<b>Analog Outputs:</b>	10V, 5V, 1V, 0.1V, selectable
<b>Lag Time:</b>	20 seconds	<b>Recorder Offset:</b>	±10%
<b>Rise and Fall Time:</b>	< 120 seconds	<b>RS232:</b>	Standard DB9 connector
<b>Linearity:</b>	1% of full scale	<b>Status (Digital)</b>	8 outputs, 6 inputs (opto-isolated), 4 alarm outputs (optional)
<b>Sample Flow Rate:</b>	650 cc/min ±10 %	<b>Current Output:</b>	Optional 4-20 mA isolated outputs (select up to 3 channels)
<b>Converter Temperature:</b>	<b>101E:</b> 315°C; <b>102E:</b> 850°C	<b>Approvals</b>	CE

NOTE: The values expressed above are in accordance with EPA definitions. All error specifications are based on constant conditions.

### Schematic

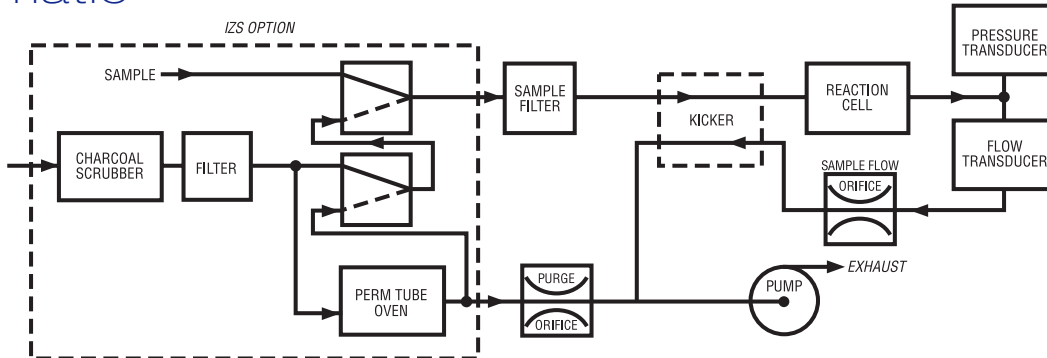

### How to Order

#### Models 101E and 102E H<sub>2</sub>S and TRS Analyzers include:

- Readout in H<sub>2</sub>S or SO<sub>2</sub> (Model 101E)
- Readout in TRS or SO<sub>2</sub> (Model 102E)
- Pump
- Auto ranging and dual ranges
- 47mm diameter particulate filter
- 8 isolated digital status outputs
- Bi-directional RS-232
- 6 isolated digital control inputs

#### Specify input AC voltage & frequency:

- 100V – 115V       50Hz
- 220V – 240V       60Hz

#### Specify output DC voltage:

- 10V     5V     1V     0.1V
- 0-20 mA or 4-20 mA isolated

#### Particulate Filter:

- 47 mm (standard)

#### Optional Equipment:

- Time-shared switching of H<sub>2</sub>S/SO<sub>2</sub> includes sample and hold providing separate analog outputs for H<sub>2</sub>S and SO<sub>2</sub> (Model 101E)
- Time-shared switching of TRS/SO<sub>2</sub> includes sample and hold providing separate analog outputs for TRS and SO<sub>2</sub> (Model 102E)
- Rack mount brackets (19") with chassis slides

- Rack mount brackets only
- Isolated 0-20mA or 4-20 mA output (specify channels)
- Multi-drop RS-232 connection
- Concentration alarms
- TFE valves for selection of customer-supplied zero and span gas
- Internal zero and permeation tube oven for calibration check. Requires permeation tube.

#### Accessories:

- RS-232 Cable
- Expendables Kit
- Spare Parts Kit

Specifications subject to change without notice. M101E/M102E/08.07



**TELEDYNE INSTRUMENTS**  
Advanced Pollution Instrumentation

A Teledyne Technologies Company

9480 Carroll Park Drive ■ San Diego, CA 92121-5201  
Ph. 858-657-9800 Fax 858-657-9816  
Email [api-sales@teledyne.com](mailto:api-sales@teledyne.com)

For more information about the Teledyne API family of monitoring instrumentation products, call us or visit our website at

[www.teledyne-api.com](http://www.teledyne-api.com)

